

# JAMAICAN JERK INSPIRED RUB • ALL NATURAL\* CHICKEN THIGHS

CONTAINS UP TO 5% RETAINED WATER AND JUICES



MADE WITH CHICKEN HATCHED,  
RAISED & HARVESTED IN THE USA  
WITH **NO ANTIBIOTICS-EVER\*\***



- Traditionally Seasoned, Flame-Grilled Chicken Thighs
- Serves up to 4 people
- Slow cooked for over 3 hours
- 100% Vegetarian Fed and Antibiotic Free
- Refrigerator-to-Table in under 15 minutes

- **Shelf Life:** 60 days while maintained at 40° F or Below
- **Piece Weight:** 20 OZ
- **Case Size:** 6 packages per case
- **Pallet Configuration:** 12 cases per layer, 84 cases per pallet

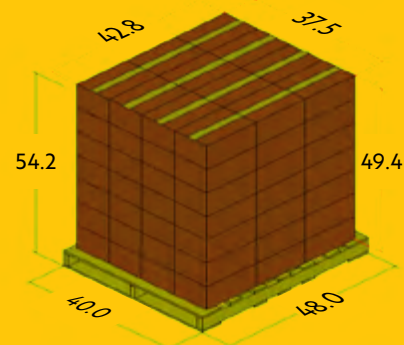

Agostino  
FOODS™

PLACE YOUR ORDER TODAY!

800-755-9840 • WWW.AGOSTINOFOODS.COM

# JAMAICAN JERK INSPIRED RUB

## ALL NATURAL\* CHICKEN THIGHS

CONTAINS UP TO 5% RETAINED WATER AND JUICES

### REHEATING INSTRUCTIONS

#### OVEN

- Preheat oven to 425°F.
- Open package and place chicken in an oven-safe pan.
- Heat for 10-12 minutes.

#### MICROWAVE

- Remove from package and place in microwave-safe pan.
- Heat for 2-3 minutes, checking halfway through until hot.

\*Note, heating times may vary based on microwave wattage.

**INGREDIENTS:** Chicken, Seasoning (Salt, Sugar, Onion, Garlic, Spices, Paprika).

### Nutrition Facts

4 servings per container	
<b>Serving size</b>	<b>5oz (142g)</b>
Amount per serving	
<b>Calories</b>	<b>310</b>
% Daily Value*	
<b>Total Fat</b> 23g	<b>30%</b>
Saturated Fat 6g	<b>32%</b>
TransFat 0g	
<b>Cholesterol</b> 140mg	<b>46%</b>
<b>Sodium</b> 200mg	<b>9%</b>
<b>Total Carbohydrate</b> 1g	<b>0%</b>
Dietary Fiber 0g	<b>0%</b>
Total Sugars 0g	
Includes 0g Added Sugars	<b>0%</b>
<b>Protein</b> 23g	
Vitamin D 0.1mcg	0%
Calcium 10mg	0%
Iron 1.1mg	6%
Potassium 290mg	6%

\*The % Daily Values (DV) tells you how much a nutrient in a serving of food contributes to a daily diet. 2,000 calories a day is used for general nutrition advice.



### WAYS TO ENJOY...

Serve with a side of potato wedges or vegetable medley!



**NET WT 20 OZ**  
**(1.3 LB)**

\*No Artificial Ingredients.

\*\* Chicken Never Administered Antibiotics.

### SAFE HANDLING INSTRUCTIONS

This product was prepared from inspected and passed meat and/or poultry. Some food products may contain bacteria that could cause illness if the product is mishandled or cooked improperly. For your protection, follow these safe handling instructions.



Keep refrigerated.



Keep raw meat and poultry separate from other foods. Wash surfaces including cutting boards, utensils, and hands after touching meat or poultry.



Cook thoroughly.



Keep hot foods hot. Refrigerate leftover immediately or discard.



LEARN MORE



**Agostino**  
**FOODS™**

**PLACE YOUR ORDER TODAY!**

800-755-9840 • WWW.AGOSTINOFOODS.COM